

225 DUAL SIDED CAM HANDLE

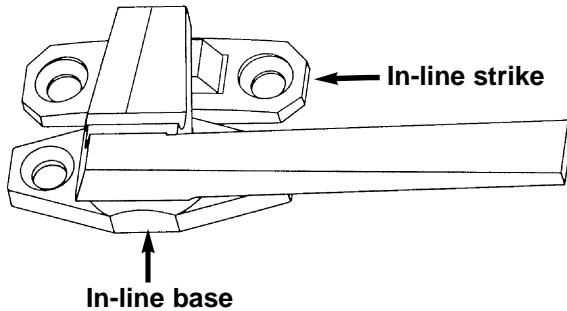

Projected **C**asement

Part # 225-030



Part # 225-029

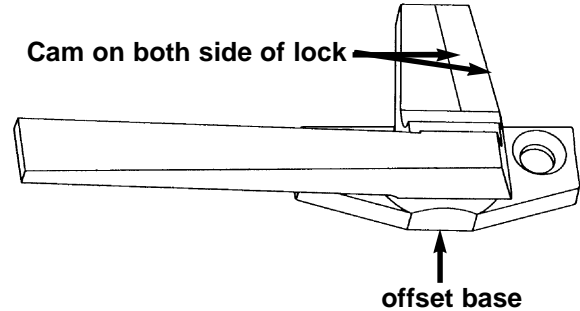

DEAL's dual sided cam handles are perfectly designed for use in both out-ward and in-ward opening windows. This dual sided cam reduces inventory and increases application of the same product in various window systems that are projected, as can be seen by the applications below.

A range of strikes and keepers further allow the lock to be used in almost any profile design.

MATERIAL: High pressure zinc die-cast handle, base and strike housing. Keepers made of high strength painted steel.

FINISH: Phosphate coated then polyester powder coated to resist chipping and flaking.

REPLACES: Truth 25 series cam handle system.

ORDERING INFORMATION:
225-031 for handle with inline base.
225-029 for handle with offset base.

Determine strike/keeper part number from the other side of this brochure.

Determine left or right hand, by the direction the handle points in the locked position, when viewed from the inside, on a projected-out bottom window.

APPLICATIONS:

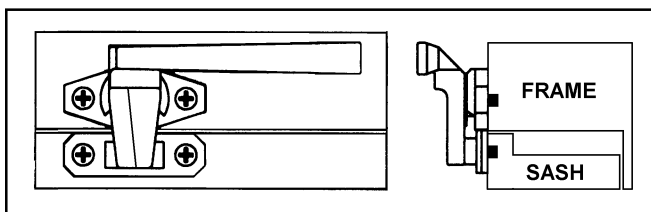

Casement / Awning when sash is flush with frame.

NOTE: The lock can also be mounted on the sash instead of the frame to allow the handle to be used as a pull in/out handle.

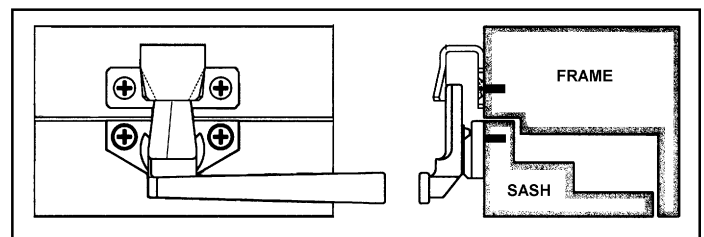

Hopper / Basement window application.

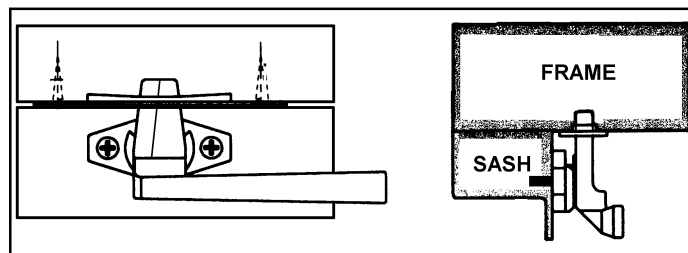

Casement / Awning when sash has overlap with frame.
 Hopper / Basement application also.

225 DUAL SIDED CAM HANDLE

FIG.1 DUAL SIDED CAM HANDLE (offset base) RH:225-029 & LH:225-028

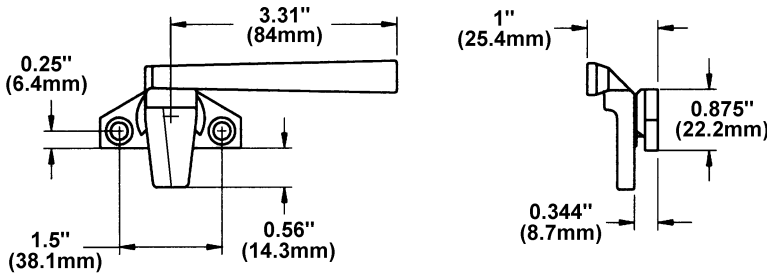

SCREW: 2- #10 Phillips, Flat head.
RIGHT HAND SHOWN HERE

FIG.2 DUAL SIDED CAM HANDLE (in-line base) RH:225-031 & LH:225-030

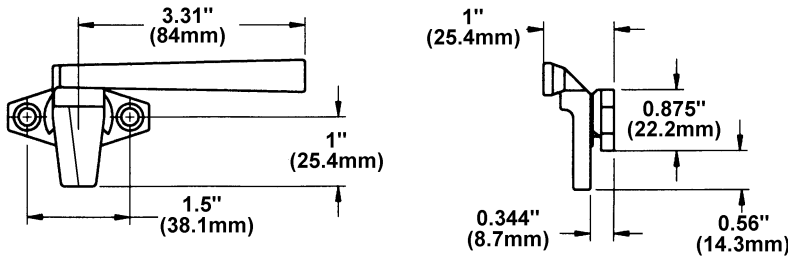

SCREW: 2- #10 Phillips, Flat head.
RIGHT HAND SHOWN HERE

FIG.3 STRIKE PLATE 299-104

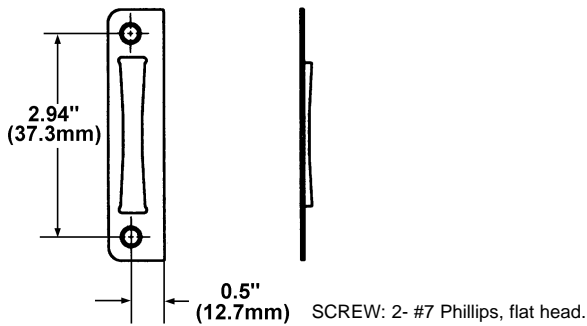
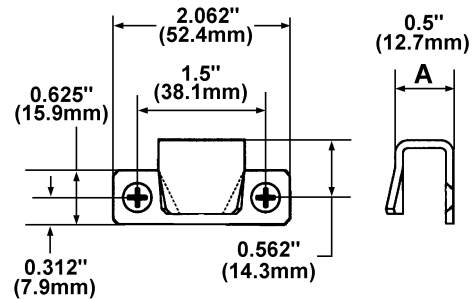
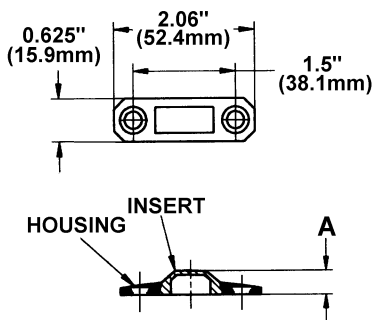

FIG.4 U-SHAPE KEEPER 299-107



NOTE: Dimension "A" will vary with profile design.
SCREW: 2- #10 Phillips, flat head.

FIG.5 IN-LINE STRIKE HOUSING 299-105



A	Part No.
0.218 (5.6mm)	299-108
0.282 (7.1mm)	299-109
0.344 (8.7mm)	299-110

SCREW: 2- #10 Phillips, flat head.

FIG.6 OFFSET STRIKE HOUSING 299-106

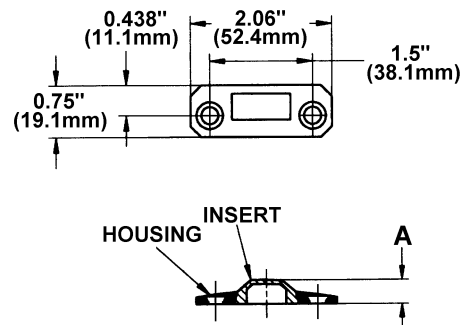

P.O. Box 10088; Rochester, NY 14610; USA
Toll free: (888) 880-DEAL (3325)

(c) 1998 DEAL International Inc. All rights reserved.

Suggestions of use should not be taken as inducement to infringe on patents. All specifications are subject to change without notice.