

224 LOCKING HANDLE

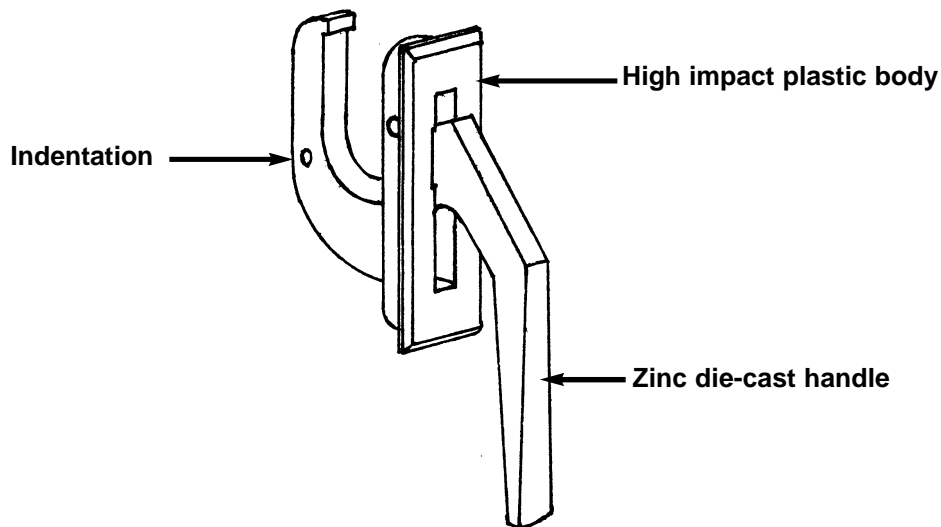

Projected **C**asement

Part # 224-021



The DEAL casement single point locking handle is a very beautifully designed locking system. It's cam action keeps pull the sash to the frame for an air tight closing. This handle achieves 7/16" of pull-in.

When open, the indentation on the side of the lock (see fig) secures the lock in the open position. This prevents the lock from falling back and locking without assistance. Vertical movement of the handle locks or unlocks the sash.

MATERIAL: High pressure zinc die-cast handle. Body made of high impact plastic. Keepers are made of stainless steel.

FINISH: Polyester powder coated to resist chipping and flaking. Custom colors available at request.

SCREWS:

Body

2 - #8 Phillips pan head self tapping screws.

Keeper

2 - #10 Phillips pan head stainless steel machine screws.

(Length and thread to be determined by profile design). We recommend that screws used to mount the keeper pass through two vinyl walls or one vinyl and one insert wall.

REPLACES: Truth 24-21 and 24-25 locking handle.

ORDERING INFORMATION:

Select the color required. Specify the part number and the color required. Finally select the mounting hardware and keepers which are sold separately.

For further information or requirements please contact us at our sales office. Address is given on the back.

224 LOCKING HANDLE

FIG. 1 LOCKING HANDLE APPLICATION

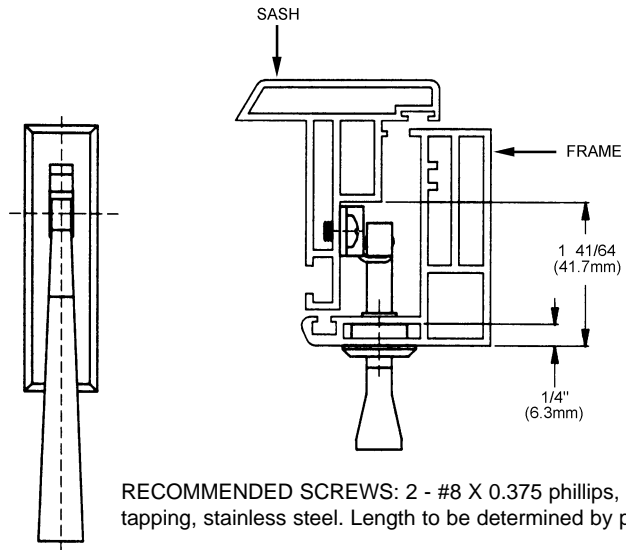
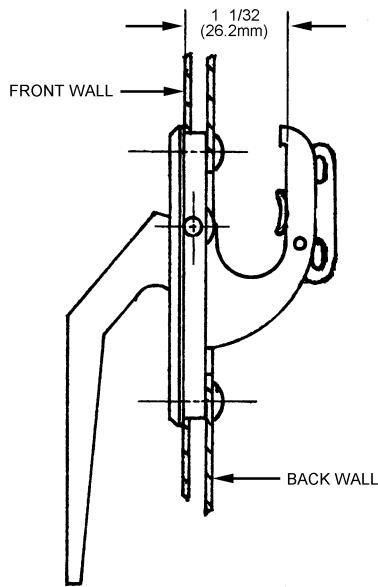

RECOMMENDED SCREWS: 2 - #8 X 0.375 phillips, pan head, self tapping, stainless steel. Length to be determined by profile.

FIG. 2 PROFILE CUT-OUT FOR HANDLE

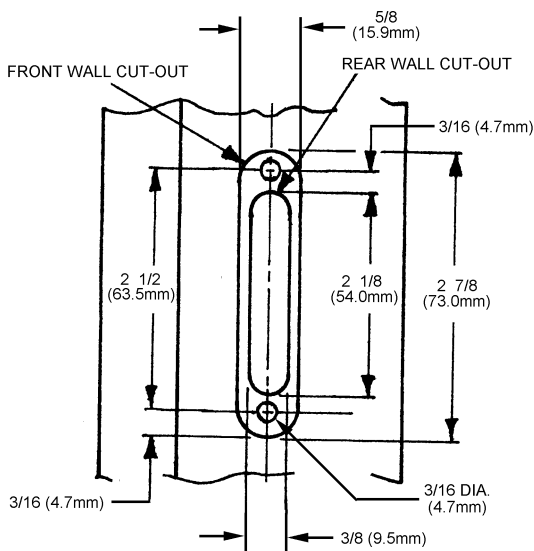
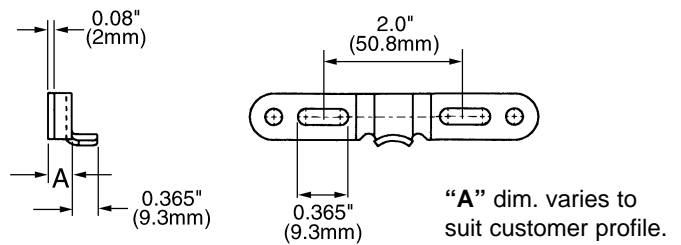

FIG. 3 STAINLESS STEEL KEEPERS



RECOMMENDED SCREWS: 2 - #10 phillips, pan head, stainless steel. Length to be determined by profile.



P.O. Box 10088; Rochester, NY 14610; USA

Toll free: (888) 880-DEAL (3325)

(c) 1998 DEAL International Inc. All rights reserved.

Suggestions of use should not be taken as inducement to infringe on patents. All specifications are subject to change without notice.