

217 FLUSH MOUNT FLANGED SASH LOCK

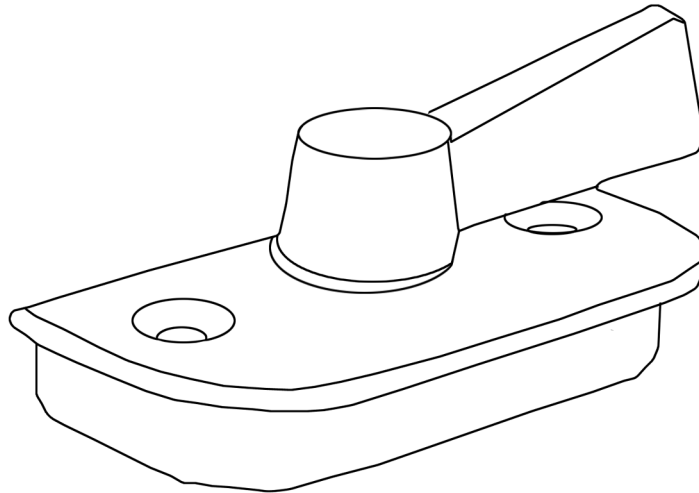

Single Hung **D**ouble hung



The flush mount flanged sash lock was designed for wood and vinyl windows. The flange is designed to hide any imperfections in the vinyl cutout. To speed the process of production a punching tool can now be used to make the cutout, instead of a machine routing it.

This lock is recessed into the sash to conceal the locking mechanism. This gives the window a very clean look and protects the moving parts from dust and dirt. It also allows the use of window grills, divided lights,

mutton bars etc. on the window without the need to notch them.

The recessed lock also gives a clean look from the outside of the window. The "Lock" directions imbossed on the lock allows the user to know when the window is locked.

This lock uses a cam that pulls the sash together 0.125" and lifts the two sash close by 0.156". Various colors and keepers are available. If you need a keeper for an application, we can tool up to meet your requirements.

MATERIAL: Lock and keeper are made of high pressure zinc die-cast which is powder coated to resist weathering, chipping and flaking.

REPLACES: Truth 17 series petite flush mount check rail lock.

ORDERING INFORMATION: Choose part Number 217-178-XX. Choose the color and keeper required.

If you need special keeper, please contact us at our sales office.

APPLICATIONS:

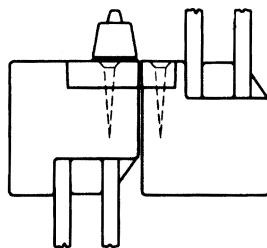

Single or Double hung window application (wood or vinyl)

217 FLUSH MOUNT FLANGED SASH LOCK

FIG.1 PETITE FLUSH MOUNT FLANGED SASH LOCK - 217-178

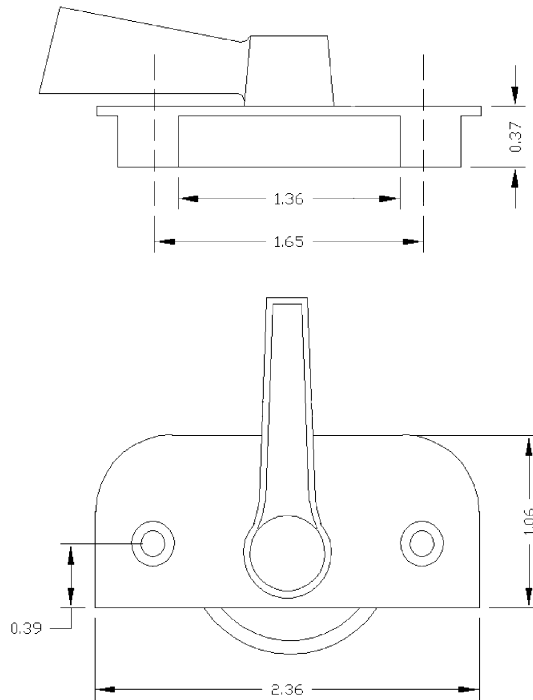

RECOMMENDED SCREWS:

WOOD WINDOWS: 2 - #6 Phillips, flat head, shank slotted, sheet metal screws.

VINYL/METAL WINDOWS: 2 - #6 Phillips, flat head screws. Length to be determined by vinyl profile.
Screw has to pass through two vinyl walls.



P.O. Box 10088; Rochester, NY 14610; USA
Toll free: (888) 880-DEAL (3325)

(c) 2006 DEAL International Inc. All rights reserved.
Suggestions of use should not be taken as inducement to infringe on patents. All specifications are subject to change without notice.