

214 CONCEALED CASEMENT HINGES

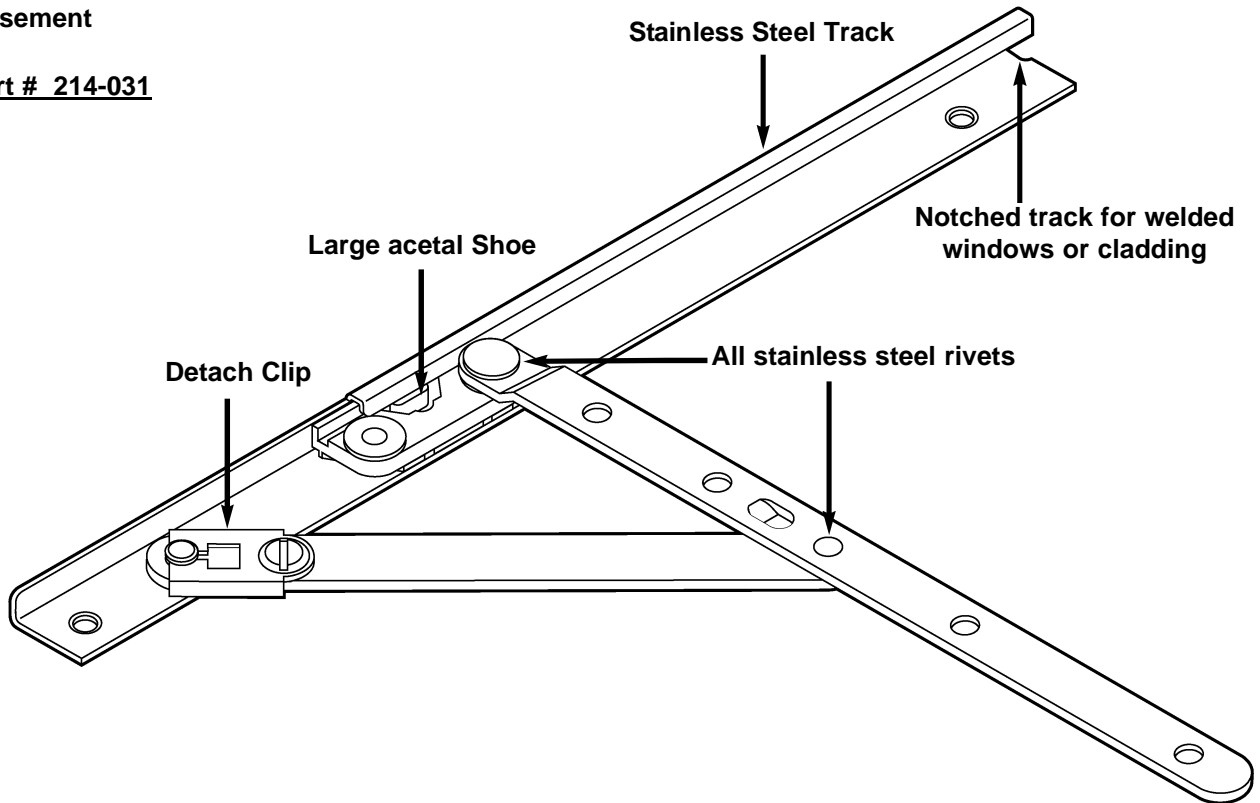

Casement

Part # 214-031



These concealed two bar hinges provide an aesthetically pleasing exterior for any casement window. These hinges are made from heavy gauge roll formed steel or 300 series stainless steel bars.

The self cleaning, high-bridge acetal shoe provides smooth sliding with no entanglement with screw heads on the SS track. SS track holes are counter sunk.

The detach clip allows the window to be easily assembled / disassembled.

MATERIAL: 300 series stainless steel track and detach clip. Heavy gauge, cold rolled steel or 300 series stainless steel sash arms. Stainless steel reinforced acetal low-friction shoe.

REPLACES:
Truth #14 series casement hinges.

ORDERING INFORMATION:
214-XXX Choose the hinge style required from the table on the other side of the brochure. These hinges are sold in pairs. One pair is required for both left and right hand window.

For further information contact us at our sales office. Address given on the other side of brochure.

APPLICATION:

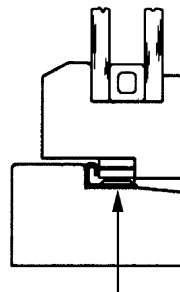

DEAL 2 Bar Hinge

Non lipped casement window application

214 CONCEALED CASEMENT HINGES

FIG. 1 TWO BAR CASEMENT HINGE

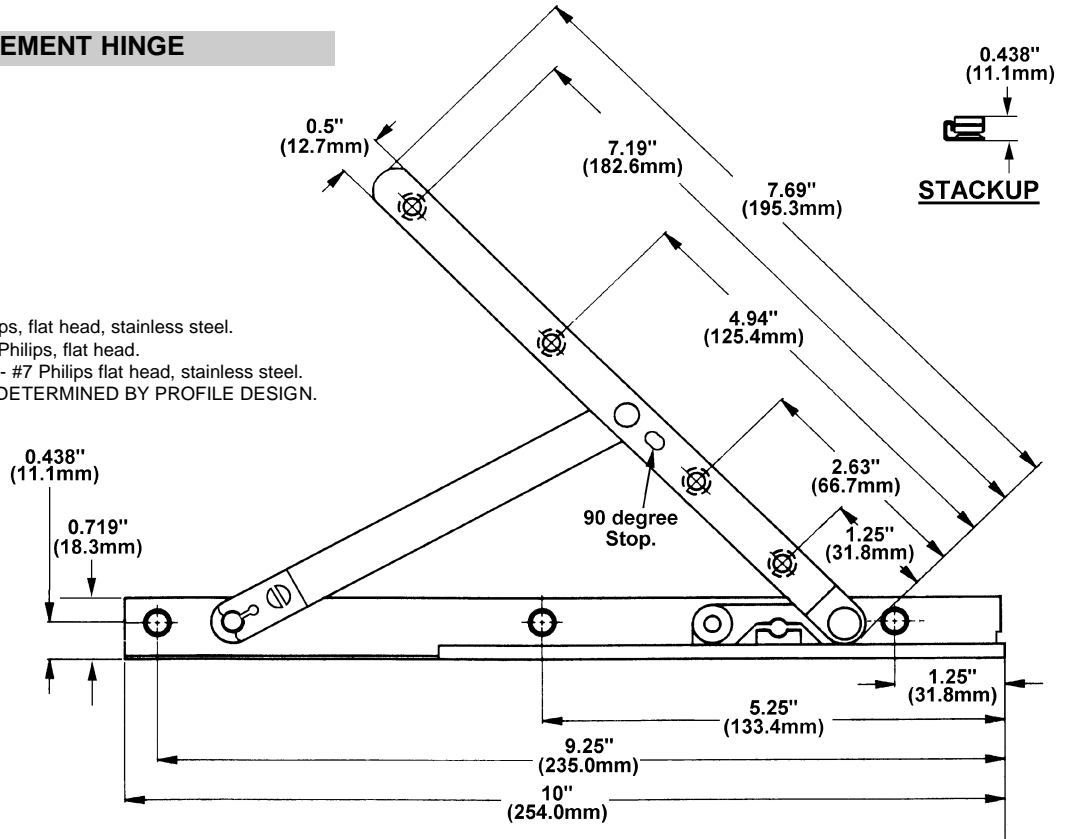

SCREWS:

TRACK: 3 PER HINGE - #7 Philips, flat head, stainless steel.
 SASH ARM: 4 PER HINGE - #7 Philips, flat head.
 SST SASH ARM: 4 PER HINGE - #7 Philips flat head, stainless steel.
 LENGTH AND THREAD TO BE DETERMINED BY PROFILE DESIGN.

FIG. 2 HINGE OPENING DIAGRAM

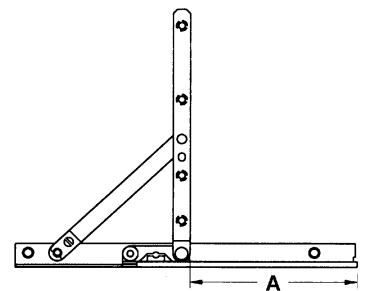

PART NO.	A	ARM MATERIAL	REPLACES TRUTH PART NO.
214-031	4.91" (124.6mm)	STEEL	14-75
214-076	5.53" (140.5mm)	STEEL	14-76
214-077(#)	2.281" (57.9mm)	STEEL	14-77
214-080	4.91" (124.6mm)	STAINLESS STEEL	14-80
214-091	5.53" (140.5mm)	STAINLESS STEEL	14-91
214-093 (#)	2.281" (57.9mm)	STAINLESS STEEL	14-93

NOTE: # - EGRESS HINGE.
 1) ALL TRACKS ARE MADE OF STAINLESS STEEL.
 2) ALL ATTACHMENT ARE CLIP TYPE.
 3) UNLESS SPECIFIED ALL HINGES HAVE 90 DEGREE STOP.



P.O. Box 10088; Rochester, NY 14610; USA
 Toll free: (888) 880-DEAL (3325)

(c) 1998 DEAL International Inc. All rights reserved.
 Suggestions of use should not be taken as inducement to infringe on patents. All specifications are subject to change without notice.